

Write your name here

Surname

Other names

Pearson Edexcel Certificate

Centre Number

Candidate Number

**Pearson Edexcel
International GCSE**

--	--	--	--	--

--	--	--	--

Chemistry

Unit: KCH0/4CH0

Science (Double Award) KSC0/4SC0

Paper: 1C

Thursday 19 May 2016 – Morning

Time: 2 hours

Paper Reference

**KCH0/1C 4CH0/1C
KSC0/1C 4SC0/1C**

You must have:

Calculator, ruler

Total Marks

Instructions

- Use **black** ink or ball-point pen.
- **Fill in the boxes** at the top of this page with your name, centre number and candidate number.
- Answer **all** questions.
- Answer the questions in the spaces provided – *there may be more space than you need.*
- Show all the steps in any calculations and state the units.
- Some questions must be answered with a cross in a box ☒. If you change your mind about an answer, put a line through the box ☒ and then mark your new answer with a cross ☒.

Information

- The total mark for this paper is 120.
- The marks for **each** question are shown in brackets – *use this as a guide as to how much time to spend on each question.*

Advice

- Read each question carefully before you start to answer it.
- Write your answers neatly and in good English.
- Try to answer every question.
- Check your answers if you have time at the end.

Turn over ►

P45728A

©2016 Pearson Education Ltd.

1/1/1/



PEARSON

THE PERIODIC TABLE

Period 1 2 3 4 5 6 7 0

Group

1	H Hydrogen 1	4 He Helium 2
---	--------------------	------------------------

2	9 Be Beryllium 4	11 B Boron 5	12 C Carbon 6	14 N Nitrogen 7	16 O Oxygen 8	19 F Fluorine 9	20 Ne Neon 10							
3	23 Na Sodium 11	24 Mg Magnesium 12	27 Al Aluminium 13	28 Si Silicon 14	31 P Phosphorus 15	32 S Sulfur 16	35.5 Cl Chlorine 17	40 Ar Argon 18						
4	39 K Potassium 19	40 Ca Calcium 20	45 Sc Scandium 21	48 Ti Titanium 22	51 V Vanadium 23	56 Fe Iron 26	59 Co Cobalt 27	65 Zn Zinc 30	70 Ga Gallium 31	73 Ge Germanium 32	75 As Arsenic 33	79 Se Selenium 34	80 Br Bromine 35	84 Kr Krypton 36
5	86 Rb Rubidium 37	88 Sr Strontium 38	89 Y Yttrium 39	91 Zr Zirconium 40	93 Nb Niobium 41	101 Ru Ruthenium 44	103 Rh Rhodium 45	112 Cd Cadmium 48	115 In Indium 49	119 Sn Tin 50	122 Sb Antimony 51	128 Te Tellurium 52	127 I Iodine 53	131 Xe Xenon 54
6	133 Cs Caesium 55	137 Ba Barium 56	139 La Lanthanum 57	179 Hf Hafnium 72	181 Ta Tantalum 73	190 Os Osmium 76	192 Ir Iridium 77	201 Hg Mercury 80	204 Tl Thallium 81	207 Pb Lead 82	209 Bi Bismuth 83	210 Po Polonium 84	210 At Astatine 85	222 Rn Radon 86
7	223 Fr Francium 87	226 Ra Radium 88	227 Ac Actinium 89											

Key

Relative atomic mass
Symbol
Name
Atomic number

DO NOT WRITE IN THIS AREA



DO NOT WRITE IN THIS AREA

DO NOT WRITE IN THIS AREA

DO NOT WRITE IN THIS AREA

Answer ALL questions.

1 The diagram shows a kettle of boiling water.

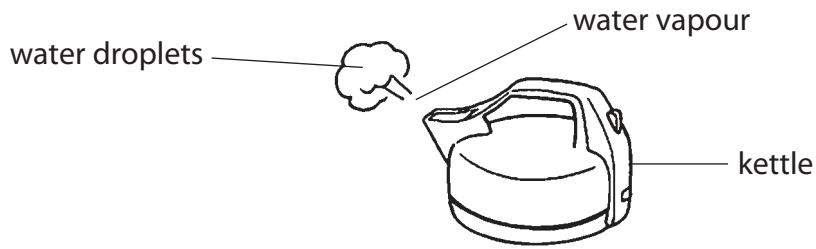

As the water vapour cools it turns into droplets of liquid water.

(a) The change of state when water vapour changes into liquid water is described as (1)

- A** boiling
- B** condensation
- C** evaporation
- D** sublimation

(b) Describe what happens when water vapour cools to form liquid water.

Your answer should include the change in the energy, arrangement and movement of the particles.

(3)

change in energy

.....
.....

change in arrangement

.....
.....

change in movement

.....
.....

(Total for Question 1 = 4 marks)



2 Air is a mixture of gases.
The two main gases present are the elements nitrogen and oxygen.

(a) Another element that is present in air is (1)

- A argon
- B carbon dioxide
- C hydrogen
- D sulfur dioxide

(b) Give the formula of a compound that is found in unpolluted air. (1)

(c) This apparatus in the diagram is used to find the percentage of oxygen in air.

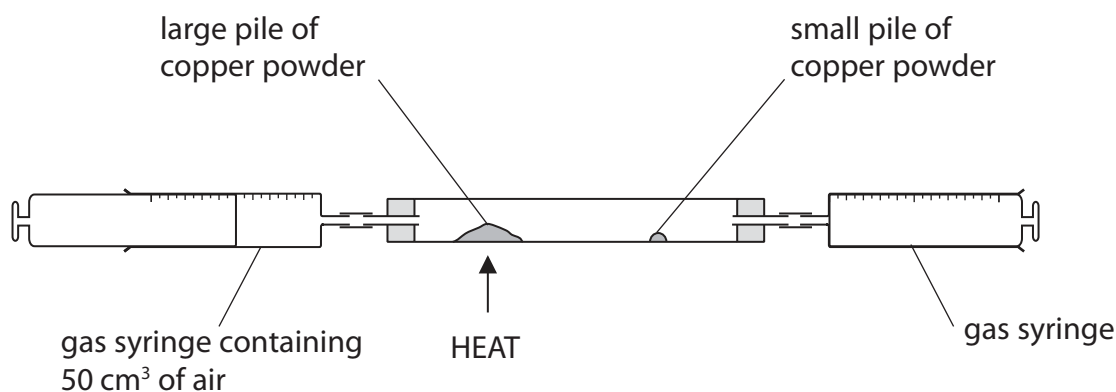

The large pile of copper powder is heated, and the air in the syringe is passed several times from one gas syringe to the other.

The large pile of copper powder turns black. The remaining gas is allowed to cool and its volume is measured.

(i) Explain why the large pile of copper turns black. (2)



(ii) Why is the gas allowed to cool before its volume is measured?

(1)

(iii) The small pile of copper powder is then heated and the remaining gas is passed several times over the hot copper. The copper does not turn black.

Suggest why the small pile of copper does not turn black.

(1)

(d) In another experiment, the total volume of air in the apparatus before heating is 150 cm³. At the end of the experiment the volume of gas remaining is 125 cm³.

Use this information to calculate the percentage of oxygen in this sample of air.

(2)

percentage of oxygen =%

(Total for Question 2 = 8 marks)

DO NOT WRITE IN THIS AREA

DO NOT WRITE IN THIS AREA

DO NOT WRITE IN THIS AREA



3 A student wants to find out if the green colouring in grass is a mixture of dyes.

He uses a solvent to dissolve the green colouring from some grass.

He then separates the solution of the green colouring from the remaining grass.

(a) Which of these methods is used to separate the solution of the green colouring from the remaining grass?

(1)

- A boiling
- B condensation
- C evaporation
- D filtration

(b) The student uses a dropping pipette to place a drop of the green solution onto a piece of chromatography paper and produces a chromatogram. The diagram shows his results.

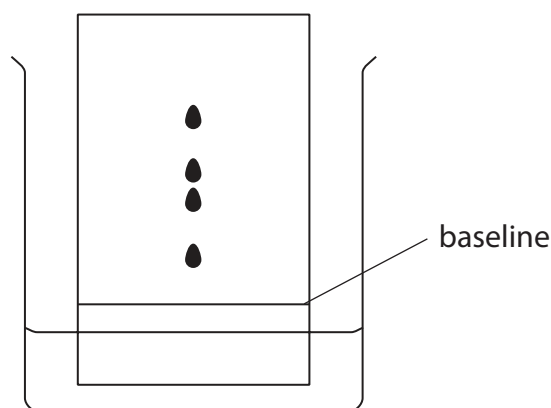

(i) Add three more labels to the diagram to show

- the solvent
- the chromatography paper
- the original position of the spot of the green solution

(3)

(ii) Explain how many different dyes are present in the green colouring.

(1)

.....

.....

.....

(Total for Question 3 = 5 marks)



4 The diagram shows the electronic configurations of six different atoms.

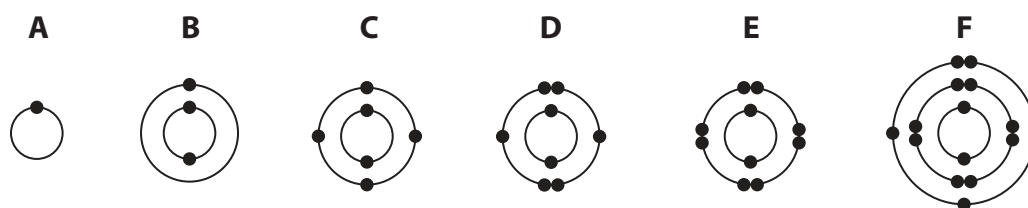

(a) You may use the Periodic Table on page 2 to help you answer this question. Answer each part by writing one of the letters A, B, C, D, E or F in the box provided.

You may use each letter once, more than once or not at all.

Give the letter that represents an atom

(6)

(i) of a noble gas

(ii) that contains three protons

(iii) of phosphorus

(iv) of an element in Group 4 of the Periodic Table

(v) of an element in Period 3 of the Periodic Table

(vi) with a full outer shell of electrons

(b) Atoms of A and D combine to form a compound containing covalent bonds.

(i) Complete the sentence to describe a covalent bond.

(2)

A covalent bond is the electrostatic attraction between a pair of

and the of two atoms.

(ii) Suggest, with reference to electronic configurations, the most likely formula of the compound formed between atoms of A and D.

(1)

(Total for Question 4 = 9 marks)

- 5 A student uses this apparatus to investigate the temperature changes that take place when certain metals are added to dilute sulfuric acid.

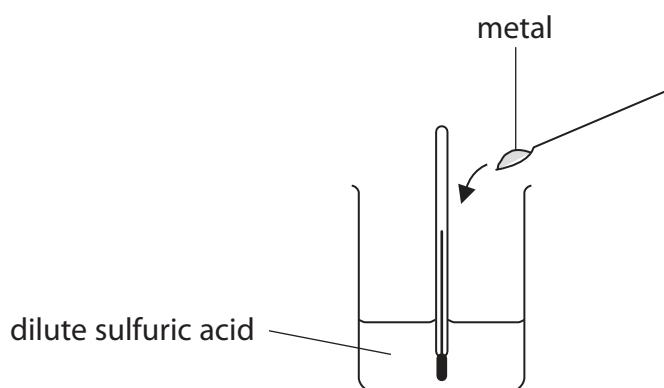

This is the student's method:

- use the five metals aluminium, copper, iron, magnesium and zinc
 - add the same amount of each metal separately to 25 cm³ of acid
 - in each case the acid is in excess
 - stir the mixture and record the highest temperature reached
- (a) Use the diagrams of the thermometer in the table to record the highest temperature reached in each experiment.

Record all temperatures to the nearest 0.5 °C.

(3)

	Metal				
	aluminium	copper	iron	magnesium	zinc
Thermometer					
Highest temperature in °C					



DO NOT WRITE IN THIS AREA

DO NOT WRITE IN THIS AREA

DO NOT WRITE IN THIS AREA

(b) (i) In each experiment the initial temperature of the acid is 25 °C.

Which metal produces the largest temperature rise?

(1)

(ii) Explain the result obtained with copper.

(1)

(c) The same amount of magnesium is added to 50cm³ of dilute sulfuric acid.

Explain the effect this would have on the temperature change observed.

(2)

(Total for Question 5 = 7 marks)



6 This question is about hydrogen (H_2) and water.

(a) Hydrogen is a gas at room temperature. It exists as simple molecules.

(i) Draw a dot and cross diagram to show the arrangement of the electrons in a hydrogen molecule.

(1)

(ii) Explain why hydrogen has a very low boiling point.

(2)

.....

.....

.....

.....

(b) The symbols for the three isotopes of hydrogen are



(i) State what is meant by the term **isotopes**.

(2)

.....

.....

.....

.....

(ii) Complete the table to show the number of protons, neutrons and electrons in each of the three isotopes of hydrogen.

(3)

	Isotope		
	${}^1\text{H}$	${}^2\text{H}$	${}^3\text{H}$
number of protons			
number of neutrons			
number of electrons			



(c) When hydrogen burns in oxygen, heat energy is transferred to the surroundings.

(i) State the name given to a reaction in which heat energy is transferred to the surroundings. (1)

(ii) Write a chemical equation to represent the reaction that takes place when hydrogen burns in oxygen. (2)

(iii) Describe a chemical test to show that the product is water. (2)

(iv) Describe a physical test to show that the product is pure water. (2)

(Total for Question 6 = 15 marks)



7 This question is about the reactions of calcium and some calcium compounds.

(a) Calcium reacts with cold water. The equation for the reaction is

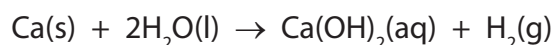

(i) State two observations that are made when calcium reacts with water.

(2)

1

2

(ii) Explain a possible value for the pH of the solution formed.

(2)

(b) The diagram shows some reactions involving calcium compounds.

Identify solid X, solution Y and solid Z.

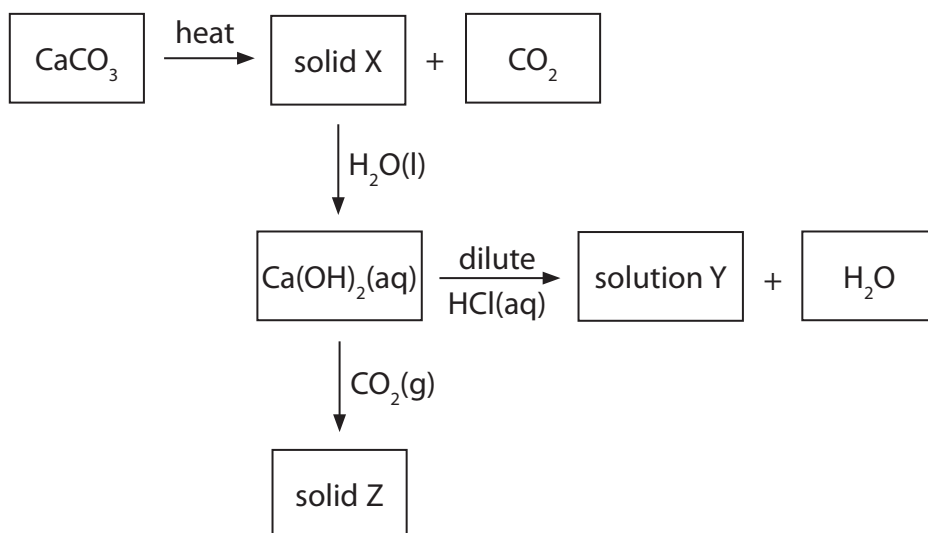

(3)

solid X

solution Y

solid Z

(Total for Question 7 = 7 marks)



DO NOT WRITE IN THIS AREA

DO NOT WRITE IN THIS AREA

DO NOT WRITE IN THIS AREA

8 The apparatus in the diagram is used to heat a sample of hydrated copper(II) sulfate crystals, $\text{CuSO}_4 \cdot 5\text{H}_2\text{O}$

The equation for the reaction that takes place is

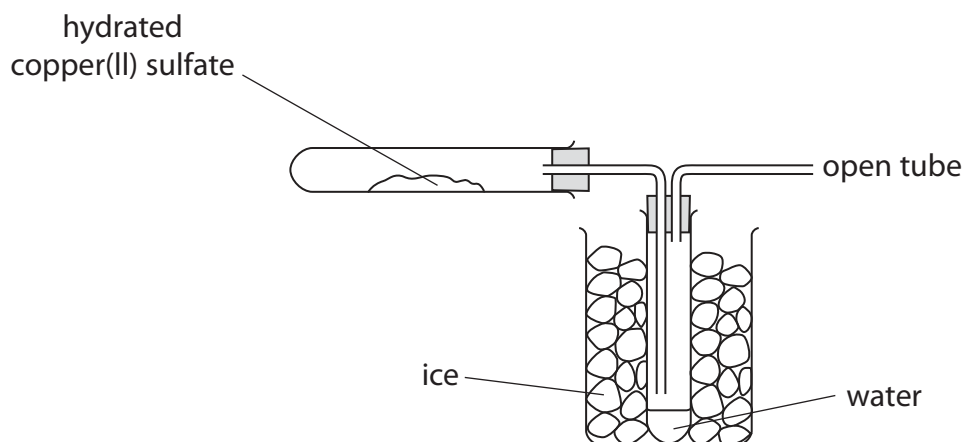

(a) Draw an arrow on the diagram to show where heat is applied. (1)

(b) What is the purpose of the ice? (1)

(c) Calculate the maximum mass of water that could be collected when a sample of hydrated copper(II) sulfate of mass 2.50 g is heated. [M_r of $\text{CuSO}_4 \cdot 5\text{H}_2\text{O}$ is 250] (3)

mass of water = g

(Total for Question 8 = 5 marks)



- 9 A student investigates the reaction of aqueous sodium hydroxide with two different aqueous solutions of hydrochloric acid, solution X and solution Y.

She carries out two experiments.

Experiment 1

- Using a measuring cylinder, she pours 20 cm^3 of aqueous sodium hydroxide into a conical flask and records its temperature.
- Using a burette, she adds 5 cm^3 of solution X to the conical flask.
- She stirs the mixture with the thermometer and records the temperature.
- She adds further 5 cm^3 volumes of solution X and stirs with the thermometer.
- She records the temperature after each addition of solution X.
- She stops when a total of 40 cm^3 of solution X has been added.

Experiment 2

- She empties the burette and rinses it first with water and then with solution Y. She then fills the burette with solution Y.
- She repeats the experiment using solution Y.

The table shows the results she obtains in Experiment 1.

Experiment 1 – Solution X	
Volume in cm^3 of solution X added	Temperature in $^{\circ}\text{C}$
0	23.0
5	27.0
10	31.0
15	32.2
20	30.6
25	28.9
30	27.3
35	25.6
40	24.0



DO NOT WRITE IN THIS AREA

DO NOT WRITE IN THIS AREA

DO NOT WRITE IN THIS AREA

- (a) Plot the results for Experiment 1 on the grid.
Draw a straight line of best fit through the first three points and a second straight line of best fit through the last six points.

Make sure that the two straight lines cross.

(4)

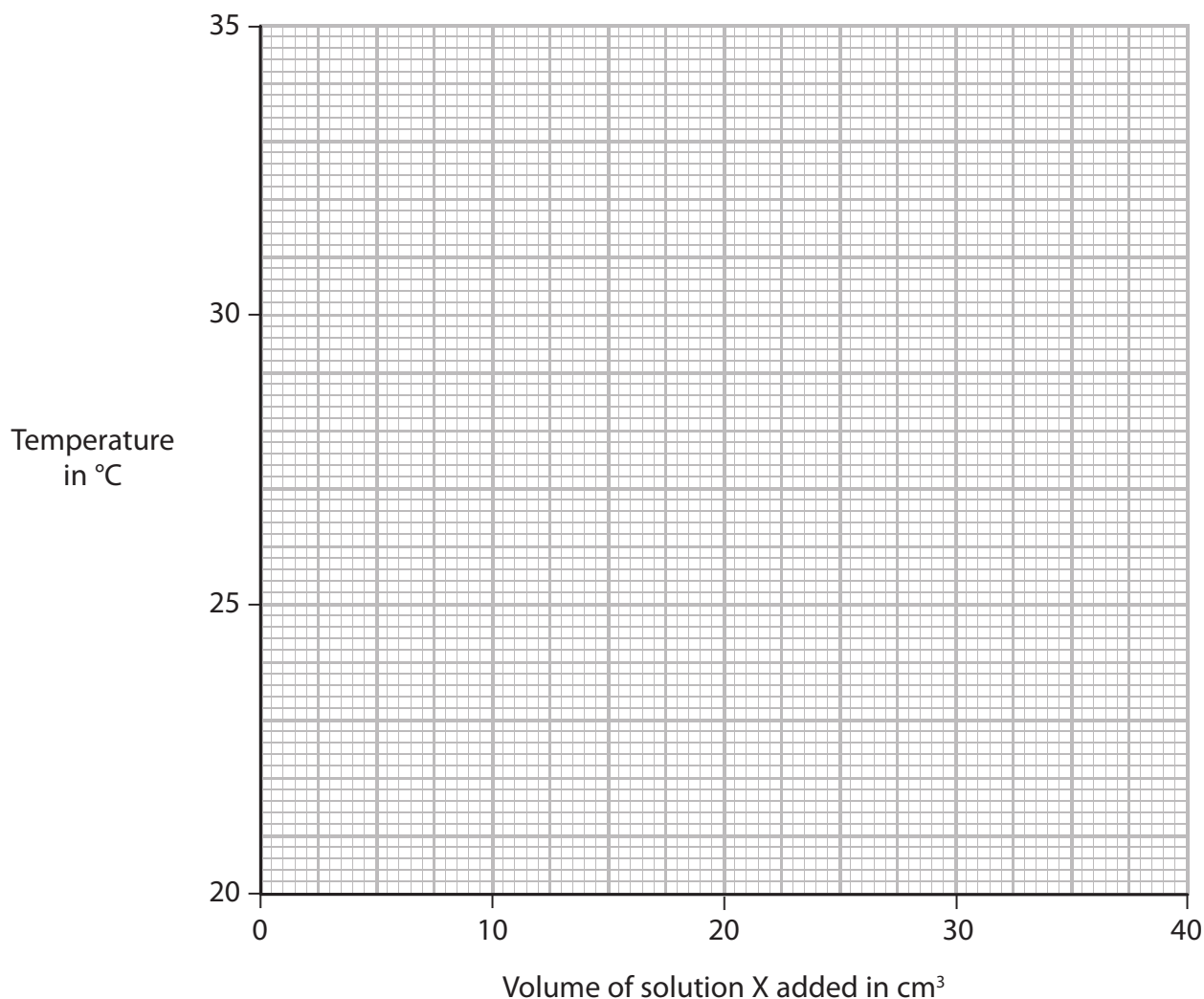

- (b) (i) Use the graph to determine the volume of solution X that will produce the maximum temperature rise when added to 20 cm³ of the aqueous sodium hydroxide.

(1)

volume of solution X = cm³

- (ii) Use the graph to determine the maximum temperature rise.

(1)

maximum temperature rise = °C



DO NOT WRITE IN THIS AREA

DO NOT WRITE IN THIS AREA

DO NOT WRITE IN THIS AREA

(c) Why did the student rinse the burette first with water, and then with solution Y, before performing Experiment 2?

(2)

water

solution Y

(d) The maximum temperature rise in Experiment 2 was less than that in Experiment 1. Suggest a reason why.

(1)

(Total for Question 9 = 9 marks)



10 This question is about hydrochloric acid.

(a) Dilute hydrochloric acid, $\text{HCl}(\text{aq})$, reacts with many metals.

A student observes the reaction of dilute hydrochloric acid with four metals, P, Q, R and S. She uses the same amount of metal in each case.

The table shows her observations.

Metal	Observations
P	very few bubbles produced very slowly
Q	many bubbles produced very quickly
R	many bubbles produced quickly
S	few bubbles produced slowly

(i) Use the information in the table to place the four metals in order of reactivity.

Place the most reactive first.

(2)

most reactive

least reactive

(ii) Give the names of the two products formed when magnesium reacts with dilute hydrochloric acid.

(2)

Product 1

Product 2

(b) Describe a test to show that dilute hydrochloric acid contains chloride ions.

(2)

.....

.....

.....

.....

(Total for Question 10 = 6 marks)

11 The table shows the displayed formulae of four hydrocarbons, W, X, Y and Z.

W	X
<pre> H H H H-C-C-C-H H H H </pre>	<pre> H H H H H-C-C-C-C-H H H H H </pre>
Y	Z
<pre> H H-C-H H H H-C-C-C-H H H H </pre>	<pre> H H \ / C / \ H C H \ / \ / C=C / \ H H </pre>

(a) Give the name of hydrocarbon W.

(1)

(b) Give the molecular formula for hydrocarbon X.

(1)

(c) Which of the hydrocarbons belong to the same homologous series of compounds?

(1)

(d) Give the empirical formula of hydrocarbon Z.

(1)

(e) Z is an unsaturated hydrocarbon.

Explain what is meant by the term **unsaturated hydrocarbon**.

(3)

unsaturated

hydrocarbon



- (f) (i) The substitution reaction between W and bromine is similar to the reaction between methane and bromine.

Suggest the displayed formula for a possible product of the reaction between W and bromine.

(1)

- (ii) State the condition required for this reaction to take place.

(1)

(Total for Question 11 = 9 marks)

DO NOT WRITE IN THIS AREA

DO NOT WRITE IN THIS AREA

DO NOT WRITE IN THIS AREA



12 Titanium is a metal that can be extracted from its ore in a three-stage process.

- stage 1 titanium ore is converted into titanium dioxide, TiO_2
- stage 2 titanium dioxide is then converted into titanium chloride, TiCl_4
- stage 3 titanium chloride is converted into titanium, Ti

(a) A titanium ore contains the composition by mass

$$\text{Fe} = 36.8\% \quad \text{Ti} = 31.6\% \quad \text{O} = 31.6\%$$

Show by calculation that the empirical formula of this ore is FeTiO_3

(3)

(b) The equation for the conversion of titanium dioxide into titanium chloride is



Explain which element has been oxidised in this reaction.

(2)

.....

.....

.....

.....



(c) In stage 3

- titanium chloride vapour is passed through molten magnesium in an atmosphere of argon
- the products are allowed to cool to form a solid mixture of titanium and magnesium chloride
- this mixture is crushed into a powder and then added to water to dissolve the magnesium chloride

(i) Write a chemical equation for the reaction between titanium chloride and magnesium. (2)

(ii) Suggest why this reaction cannot be successfully carried out in an atmosphere of air. (1)

(iii) Suggest why the mixture is crushed into a powder before it is added to water. (1)

(d) (i) Describe the bonding in titanium metal. (2)

(ii) Explain why titanium conducts electricity. (1)

(Total for Question 12 = 12 marks)



13 Iodine reacts with chlorine to form iodine monochloride, ICl

(a) Write a chemical equation for this reaction.

(1)

(b) Iodine monochloride reacts reversibly with chlorine to form iodine trichloride.

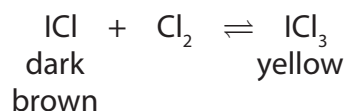

The reaction mixture is allowed to reach a state of dynamic equilibrium.

(i) One feature of a reaction that is in dynamic equilibrium is that both the forward reaction and the backward reaction occur simultaneously.

Give two other features of a reaction that is in dynamic equilibrium.

(2)

1

.....

2

.....

(ii) When the equilibrium mixture is heated, it becomes darker brown in colour.

Explain whether the backward reaction is exothermic or endothermic.

(2)

.....

.....

.....

.....

.....

(Total for Question 13 = 5 marks)



14 Potassium hydrogencarbonate (KHCO_3) decomposes on heating.

Three possible equations for the decomposition are

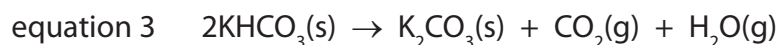
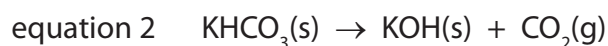
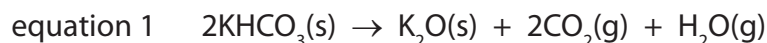

When 8.00 g of potassium hydrogencarbonate is heated until it is fully decomposed, 5.52 g of solid is formed.

(a) Complete the table by calculating the amount, in moles, of each solid.

(2)

Solid	M_r of solid	Mass of solid in g	Amount of solid in mol
KHCO_3	100	8.00	
K_2O	94	5.52	
KOH	56	5.52	
K_2CO_3	138	5.52	

(b) Use the information in the table to explain which equation, 1, 2 or 3, represents the decomposition of potassium hydrogencarbonate.

(2)

.....

.....

.....

.....

.....

.....

.....

.....

(Total for Question 14 = 4 marks)



15 Butane (C_4H_{10}) is a gas at room temperature and pressure.

The equation for the complete combustion of butane is

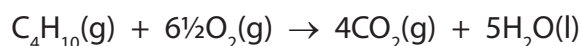

Butane is used in an experiment to determine its ΔH of combustion.

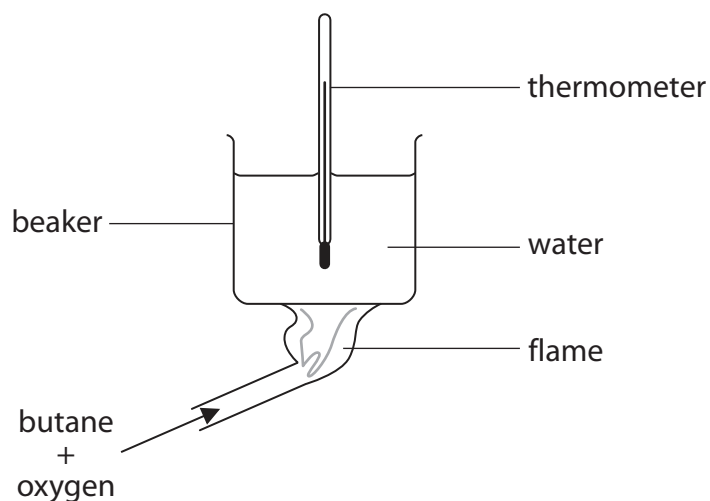

(a) State what the symbol ΔH represents.

(1)

(b) The table shows the results of the experiment.

mass of water heated	200 g
mass of butane burned	0.725 g
initial temperature of water	20.2 °C
final temperature of water	43.7 °C

Use this equation to calculate the heat produced when 0.725 g of butane is burned in this experiment.

$$\text{heat produced (in J)} = \text{mass of water (in g)} \times 4.2 \times \text{temperature rise of water (in } ^\circ\text{C)}$$

(3)

heat produced = J



(c) A student uses the value from part (b) to calculate ΔH for the combustion of butane. He calculates it as -1580 kJ/mol . He has not made a mistake in his calculation. A data book value is -2887 kJ/mol .

(i) What is the significance of the negative sign for ΔH ? (1)

.....
.....

(ii) The student notices that at the end of the experiment the bottom of the beaker is covered in black soot (carbon). Suggest how this soot is formed. (1)

.....
.....

(iii) Explain how the formation of the soot may account for the difference between the value of ΔH from the experiment and the value of ΔH in the data book. (1)

.....
.....

(iv) Suggest one other reason why the two ΔH values are different. (1)

.....
.....
.....

(Total for Question 15 = 8 marks)



16 The diagram shows the apparatus used to investigate the rate of reaction between calcium carbonate and an excess of dilute hydrochloric acid.

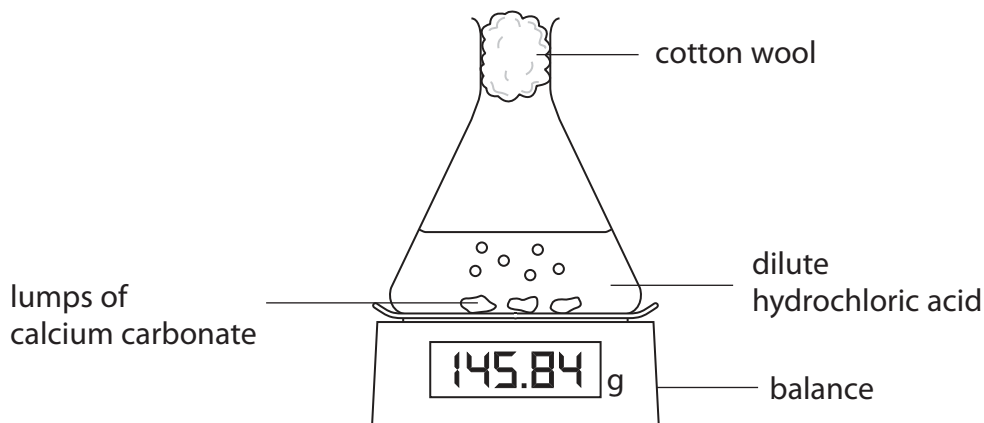

The mass of the flask and contents is measured at regular time intervals.

The graph shows the results obtained.

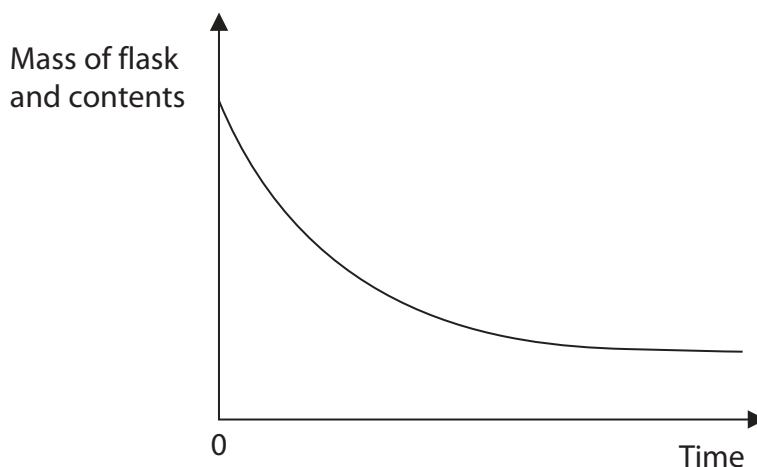

(a) What is the purpose of the cotton wool in the neck of the flask? (1)

.....

.....

(b) Explain why the mass of the flask and contents decreases with time. (1)

.....

.....



(c) (i) The experiment is repeated using

- the same mass of identical calcium carbonate lumps
- the same volume of hydrochloric acid but of a higher concentration

Sketch on the graph the curve that would be produced.

(2)

(ii) Explain, using the particle collision theory, how the rate of reaction changes with an increase in concentration of hydrochloric acid.

(3)

.....

.....

.....

.....

.....

.....

.....

(Total for Question 16 = 7 marks)

TOTAL FOR PAPER = 120 MARKS



DO NOT WRITE IN THIS AREA

DO NOT WRITE IN THIS AREA

DO NOT WRITE IN THIS AREA

BLANK PAGE

Every effort has been made to contact copyright holders to obtain their permission for the use of copyright material. Pearson Education Ltd. will, if notified, be happy to rectify any errors or omissions and include any such rectifications in future editions.

